

E 500 S-Maschinenkörper/Machine Body/Corpo macchina/Machine

**E 500 S – Maschinenkörper / Machine Body / Corpo macchina / Machine**

Pos	Art.Nr.	Stück	Bezeichnung	Description	Descrizione	Designation
			Maschinenkörper E 500 S	Machine body E 500 S	Corpo macchina E 500 S	Machine E 500 S
1	20056400	1	Schutzring	safety ring	anello paracolpi	Anneau de protection
2	20413206	1	Schutzhaube lang, chrom	cover, chrom	copertura cromata	Capot
3	20036000	3	Linsenschraube CM5x10	screw CM5x10	vite CM5x10	Vis CM5x10
4	20029700	1	Sicherungsring I 10x1	safety ring I 10x1	anello di protezione I 10x1	Circlips I 10x1
5	20413501	1	Kühlflügel	cooling fan	ventola di raffreddamento	Ventilateur
6	20010500	2	Zylinderschraube M4x16	cap screw M4x16	vite cilindrica M 4x16	Vis cylindrique M4x16
7	20060000	2	Zahnscheibe J4,3	lock washer J4,3	rondella dentata J4,3	Rondelle J 4,3
8	20413701	1	Toleranzring BN12x12	ring BN12x12	anello di tolleranza BN12x12	Anneau BN12x12
9	20444431	1	Motorgehäuse mit Stator P80	motorhousing with stator P80	coppa motore con statore P80	Boîte moteur avec stator P80
10	20278800	4	Zylinderschraube EM5x35	cap screw EM5x35	vite cilindrica EM5x35	Vis cylindrique EM5x35
11	20045200	1	Ausgleichscheibe	washer	rondella	Rondelle
12	20006000	1	Rillenkugellager 6001 2RS	bearing 6001 2RS	cuscinetto 6001 2RS	Roulement 6001 2RS
13	20037600	1	Fliehkraftschalter	centrifugal switch	disgiuntore	Interrupteur centrifuge
14	20444831	1	Rotor P80	rotor P80	rotore P80	Rotor P80
15	20530332	1	Austauschgetriebe 3PL	planetary gear replaced	ingranaggio satellitare	Engrenage planétaire
16	20413601	1	Kantenschutz	gasket	profilo di protezione	Protection
17	20088500	1	Betriebskondensator 30 µF	capacitor 30 µF	condensatore 30 µF	Condensateur de travail 30µF
18	20144800	1	Anlaßkondensator 150 µF	starting condenser 150 µF	condensatore di spunto 150 µF	Condensateur de démarrage 150µF
19	20544200	1	Isolierfolie	terminal insulation	lamina isolante	Isolation
20	20026400	2	Bolzen für Tragegriff	bolt for handle	bullone	Boulon
21	20026500	2	Tragegriff	carrying handle	maniglia trasporto	Poignée
22	20412700	1	Gegengewicht	counterweight	contrappeso	Contre poids
23	20000700	2	Scheibe 6,4	washer 6,4	rondella 6,4	Rondelle 6,4
24	20035700	2	Zylinderschraube M6x30	cap screw M6x30	vite cilindrica M6x30	Vis cylindrique M6x30
25	20161300	1	Kabelbinder	cable strip	strip cavo	Attache rapide
26	20135800	1	Spannband	strip	fascetta	Bande
27	20010800	1	Linsenschraube M4x8	screw M4x8	vite M4x8	Vis M4x8
28	20018400	2	Linsenschraube M3x16	screw M3x16	vite M3x16	Vis M3x16
29	20409300	1	Klemmleiste 4-pol	terminal 4 poles	morsettiera 4 poli	Domino à 4-pôles
30	20036000	2	Linsenschraube CM5x10	screw CM5x10	vite CM5x10	Vis CM5x10
31	20412901	1	Schaltkasten Oberteil, blau	switch box upper part, blue	cassetta interruttori superiore, blu	Boîtier partie inférieur, bleu
32	20000300	4	Scheibe 4,3	washer 4,3	rondella 4,3	Rondelle 4,3
33	20010800	4	Linsenschraube M4x8	screw M4x8	vite M4x8	Vis M4x8
34	20530000	1	Gerätesteckdose 10A	socket 10A	presa 10A	Prise femelle 10A
35	20530100	1	Gerätestecker	plug	spina	Prise mâle
36	20159300	1	Linsenschraube M4x6	screw M4x6	vite M4x6	Vis M4x6

**E 500 S – Maschinenkörper / Machine Body / Corpo macchina / Machine**

Pos	Art.Nr.	Stück	Bezeichnung	Description	Descrizione	Designation
37	20060000	1	Zahnscheibe J4,3	lock washer J4,3	rondella dentata J4,3	Rondelle J 4,3
38	20413001	1	Schaltkasten Unterteil, blau	switch box lower part, blue	cassetta interruttori inferiore, blu	Boîtier partie supérieur, blue
39	20023000	1	Schlauchtülle	hose sleeve	portatubo	Douille
40	20279900	2	6-Kt.Schraube M8x50	hex.screw M8x50	vite esagonale M8x50	Vis 6-pans M8x50
41	20045900	2	Verbusmutter M8	hex.nut M8	dado M8	Ecrou M8
42	20412601	1	Blockergehäuse E500	housing E500	piatto macchina E500	Chassis pour machine E500
43	20070000	4	6-Kt.Mutter M6 STOPP	hex.nut M6 STOPP	dado esagonale M6 STOPP	Ecrou M6 STOPP
44	20009300	1	6-Kt Mutter M12x1	hex.nut M12x1	dado esag. M12x1	Ecrou M12x1
45	20031300	1	Stoßring E500	bumper E500	paracolpi E500	Anneau de protection E500
46	20057000	1	Zwischenscheibe	intermediate ring	distanziale	Rondelle interméd.
47	20062000	3	Anschlagstück	rubber piece	scodellino	Arrêt
48	20057200	3	Mitnehmerbolzen	catch bolt	perno	Boulon
50	20574000	1	Segmentscheibe	segment ring	flangia	Anneau
51	20058900	1	Zentrierring	centring ring	anello di centraggio	Anneau de centrage
52	20008000	6	Zahnscheibe J6,4	lock washer J6,4	rondella dentata J6,4	Rondelle J 6,4
53	20567500	6	Zylinderschraube M6x14	cap screw M6x14	vite cilicdrca M6x14	Vis cylindrique M6x14
54	20369600	1	Stopfen	closure	tappo	Bouchon
	70014100	1	Firmenschild	decal	etichetta columbus	
56	20544331	1	Bürstaufnahme klein	brush holder assy	flangia piccola	Fixation de brosse

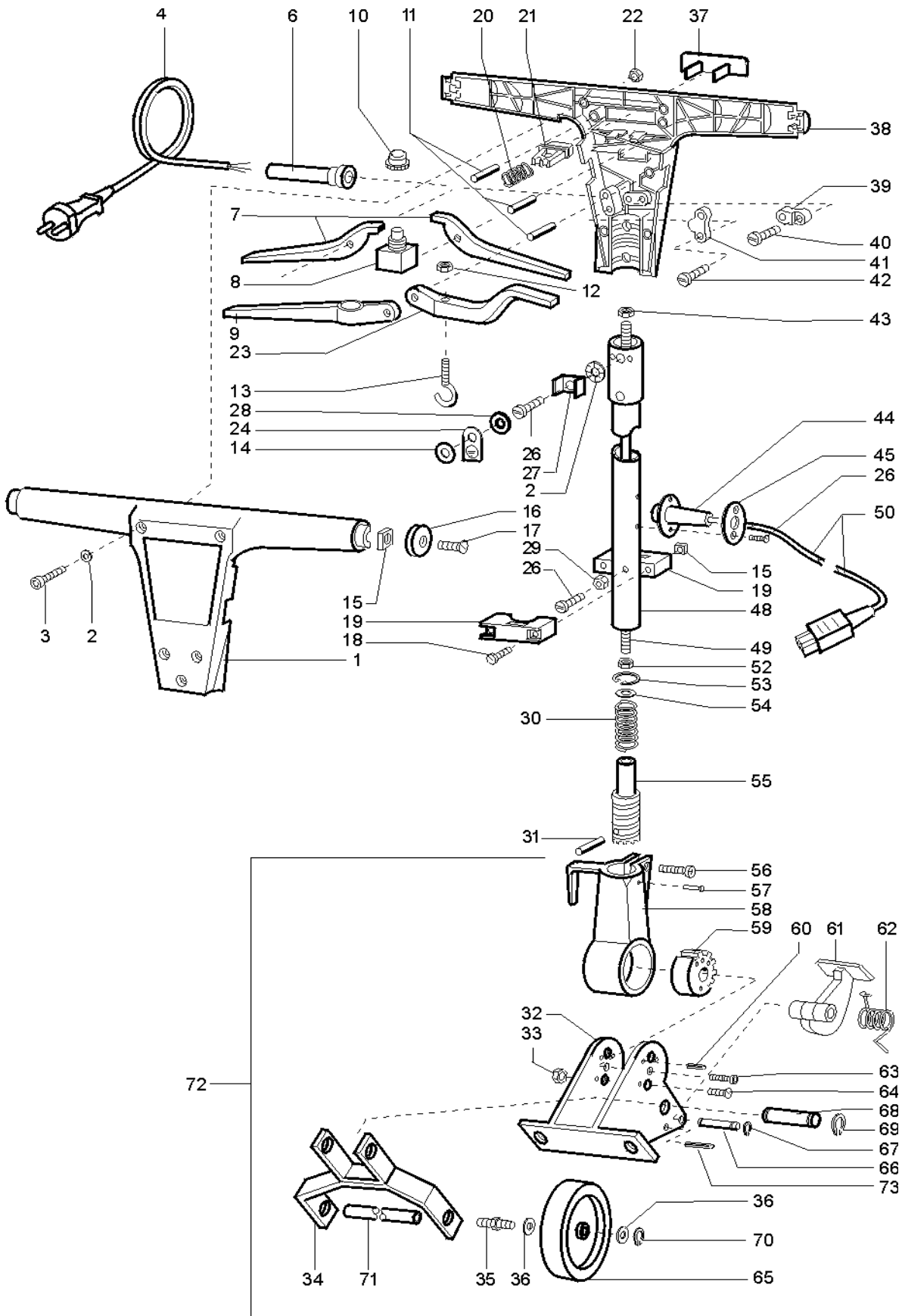

## E 500 S-Führungsstange/Handle/Timone/Timon

Pos.	Artikel Nr.	Stück	Bezeichnung	Description	Descrizione	Designation
			Führungsstange mit Fahrgestell	Handle with wheels	Timone con carrello	Timon avec roulette
1	20040201	1	Schalterschale Oberteil, blau	handle upper	scatola impugnatura posteriore	Poignée
2	20030100	7	Schnorr-Sicherung M6	safety ring M6	rondella Schnorr M6	Anneau de sécurité M6
3	20030000	6	Zylinderschraube M6x40	cap screw M6x40	vite cilindrica M6x40	Vis cylindrique M6x40
4	20588800	1	Anschlußleitung mit Stecker 12m	power cable 12m	cavo alimentazione con spina 12m	Câble d'alimentation 12m
	20035200	1	Anschlußleitung mit Stecker 12m	power cable 12m	cavo alimentazione con spina 12m	Câble d'alimentation 12m CH
6	20013900	1	Knickschutzfülle	cable sleeve	passacavo	Douille
7	20025900	2	Schalthebel	connection lever	leva interruttore	Levier de commande timon
8	20029800	1	Drucktaster	switch	pulsante	Interrupteur
9	20026000	1	Stellhebel	position lever	leva comando timone	Levier de réglage timon
10	20040000	1	Gummikappe für Drucktaster	rubber cap for switch	cappuccio in gomma	Capot en caoutchouc
11	20022700	3	Zylinderstift 6M6x36	pin 6M6x36	spinotto cilindrico 6M6x36	Goupille 6M6x36
12	20002600	2	6-Kt.Mutter M4	hex. Nut M4	dado esagonale M4	Ecrou M4
13	20023900	1	Ringschraube M4	ring screw M4	vite ad anello M4	Vis M4
14	20000700	1	Scheibe 6,4	washer 6,4	rondella 6,4	Rondelle 6,4
15	20029900	6	4-Kt.Mutter M5	square nut M5	dado quadro M5	Ecrou M5
16	20028200	2	Verschlußdeckel	cover lid	coperchietto	Couvercle
17	20002800	2	Senkschraube M5x12	screw M5x12	vite M5x12	Vis M5x12
18	20030400	4	Zylinderschraube M5x45	cap screw M5x45	vite cilindrica M5x45	Vis cylindrique M5x45
19	20026300	4	Tankträger	tank holder	supporto serbatoio	Support de réservoir
20	20040100	1	Druckfeder	tension spring	molla di pressione	Ressort
21	20040501	1	Taste	push button	tasto interruttore	Bouton poussoir
22	20002000	6	6-Kt.Mutter M6	hex nut M6	dado esagonale M6	Ecrou M6
23	20026100	1	Wasserhebel	water lever	leva serbatoio	Levier de commande d'eau
24	70015400	1	Erdungszeichen	earth plate	contrassegno messa a terra	Autocollant
26	20036500	6	Lindenschraube CM4x10	screw CM4x10	vite testa ovale CM4x10	Vis CM4x10
27	20057900	1	Klemmbügel	clamp	morsetto di fissaggio	Etrier de serrage
28	20060000	1	Zahnscheibe J4,3	lock washer J4,3	rondella dentata J4,3	Rondelle J 4,3
29	20000200	2	6-Kt.Mutter M4 flach	hex.nut M4 flat	dado esagon.piatto M4	Ecrou M4
30	20024600	1	Druckfeder	tension spring	molla tensione	Ressort
31	20179500	1	Spannhülse 4x20	sleeve 4x20	bussola 4x20	Douille 4x20
32	20024501	1	Halterung	catch, blue	supporto	Support
33	20045900	2	Verbusmutter M8	hex.nut M8	dado M8	Ecrou M8
34	20056201	1	Laufrollenhalter	catch for roller wheel, blue	staffa	Attache pour timon
35	20027000	2	Laufrollenbolzen	bolt for roller wheel	bullone	Boulon de roue
36	20047400	4	Paßscheibe 12x18x0,5	washer 12x18x0,5	rondella 12x18x0,5	Rondelle 12x18x0,5
37	20040400	1	Druckplatte	pression plate	pulsante	Support
38	20040301	1	Schalterschale Unterteil, blau	handle lower	scatola impugnatura anteriore	Boîtier partie inférieur
39	20046200	1	Zugentlastungsschelle klein	clamp, small	morsetto	Attache
40	20048000	2	Blechschrabe Bz 4,2x16	tin screw Bz 4,2x16	vite autofil. Bz4,2x16	vis Bz 4,2x16
41	20033800	1	Zugentlastungsschelle groß	clamp	morsetto	Attache

## E 500 S-Führungsstange/Handle/Timone/Timon

Pos.	Artikel Nr.	Stück	Bezeichnung	Description	Descrizione	Designation
42	20046300	2	Blechschraube Bz 4,2x19	tin screw Bz 4,2x19	vite autofil. Bz 4,2x19	Vis Bz 4,2x19
43	20046000	1	6-Kt. Mutter M5	hex .nut M5	dado esagon. M5 STOPP	Ecrou M5
44	20008600	1	Kabelmuffe mit Flansch	cable sleeve	passacavo	Douille
45	20008700	1	Flanschnapf	flange	flangia	Flange
48	20022801	1	Führungsrohr, blau	tube	asta timone	Tube timon
49	20026200	1	Zugstange	bar	asta fissaggio	Tige pour timon
50	20035200	1	Anschlußleitung 3x1x1,25m	connecting cable 1,25m	cavo alimentazione 3x1x1,25m	câble 3x1x1,25m
52	20005600	1	6-Kt. Mutter M5	hex.nut M5	dado esagonale M5	Ecrou M5
53	20030300	1	Sicherungsring A26x1,2	safety ring A26x1,2	rondella di protezione A26x1,2	anneau de sécurité A26x1,2
54	20374300	1	Scheibe 15x25x1	washer 15x25x1	rondella 15x25x1	Rondelle 15x25x1
55	20025000	1	Rastenstück	catch	attacco	Arrêt timon
56	20035700	1	Zylinderschraube EM6x30	cap screw EM6x30	vite cilindrica EM6x30	Vis cylindrique EM6x30
57	20543900	1	Linsenschraube M5x12 EJOT	screw M5x12 EJOT	vite EM6x25 EJOT	Vis EJOT M5x12
58	20025701	1	Führungsstangenhalter, blau	catch	supporto timone	Support de timon
59	20024900	1	Zahnrad	gear	corona dentata	Pignon timon
60	20029000	3	Spannhülse 6x36	clamp sleeve	bussola	Douille
61	20022401	1	Raste	catch	pedale carrello ruote	Pédale
62	20057300	1	Torsionsfeder	spring	molla di torsione	Ressort de tension
63	20029100	1	Zylinderschraube M8x55	cap screw M8x55	vite cilindrica M8x55	Vis cylindrique M8x55
64	20030800	2	Senkschraube M8x25	screw M8x25	vite M8x25 DIN 7991	Vis M8x25
65	20030600	2	Laufrolle Ø125	roller wheel Ø125	ruota Ø125	Roulette Ø125
66	20022600	1	Zylinderstift 10x55	pin 10x55	spinotto cilindrico 10x55	Goupille 10x55
67	20029700	2	Sicherungsring 10x1	safety ring 10x1	rondella di protezione 10x1	Circlips I 10x1
68	20022500	1	Zylinderstift 16x55	pin 16x55	spinotto cilindrico 16x55	Goupille 16x55
69	20029600	2	Sicherungsring 16x1	safety ring 16x1	rondella di protezione 16x1	Circlips I 16x1
70	20028900	2	Sicherungsring 12x1	safety ring 12x1	rondella di protezione 12x1	Circlips 12x1
71	20044700	1	Querstab	bar	barra trasversale	Tige pour roulette
72	20044231	1	Fahrgestell kpl.	wheel assembly	carrello ruote completo	Ensemble de roues
73	20039400	1	Spannhülse 6x45	clamp sleeve	bussola	Douille
	70014600	1	Bedienschild Führungsstange	decal	adesivo	

<b>1</b>	Schalter	switch	interruttore
<b>2</b>	Steckverbinder	socket connection	spina di contatto
<b>3</b>	Arbeitswicklung	working winding	avvolgimento primario
<b>4</b>	Fliehkraftschalter	centrifugal switch	disgiuntore
<b>5</b>	Anlaßkondensator	starting condenser	condensatore di spunto
<b>6</b>	Motor	motor	motore
<b>7</b>	Hilfswicklung	auxiliary winding	avvolgimento secondario
<b>8</b>	Betriebskondensator	condenser	condensatore
<b>9</b>	Steckdose	socket	presa

